



Crosman



M1

Owner's Manual

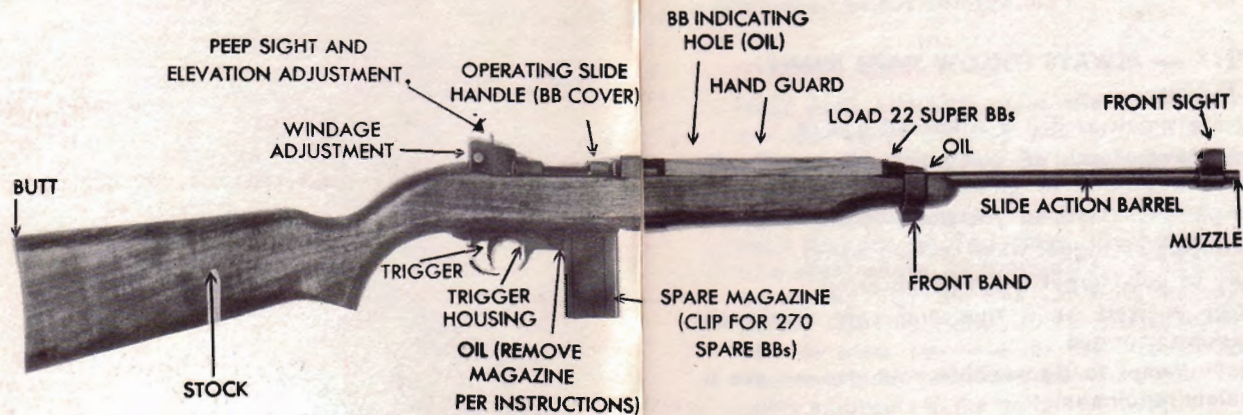
DIAGRAM OF REFERENCE POINTS



READ ALL INSTRUCTIONS CAREFULLY
and before operating gun

FOR BEST PERFORMANCE USE CROSMAN SUPER BBs®

CROSMAN M-1 CARBINE BB AIR RIFLE
22 SHOT REPEATER
(with 270 shot capacity spare magazine)

CROSMAN M-1 CARBINE BB AIR RIFLE 22 SHOT REPEATER

FOR SAFETY — ALWAYS FOLLOW THESE SIMPLE SAFETY RULES:

1. Treat every gun as if it is a loaded gun.
2. Always keep muzzle of gun pointed in a safe direction.
3. Don't point at anything you don't intend to shoot.
4. Keep fingers off trigger when cocking barrel.
5. Be sure of your target and your backstop.
6. Conduct yourself as a true and safe sportsman when using your gun.
7. Do not attempt to disassemble your gun — use a competent repairman.

The Crosman M-1 Carbine BB Air Rifle is a repeater, Slide Action Barrel Cocking with an internal magazine capacity of 22 Crosman Super BB's and a spare magazine (clip) holding an additional 270 BB's. Fast, easy, slide action operation of the barrel chambers a BB each time for rapid firing. The operating slide handle acts as a BB port cover preventing BB's from falling out of the internal magazine. Fully adjustable rear sight, with windage and elevation adjustments permits

fast and simple zeroing on the target. The front sight blade is protected from damage by two outwings. You can expect the best accuracy at 15 feet or closer. As with most BB guns, the NRA standard for BB gun targets is established at this distance.

1. TO LOAD RIFLE:

FIRST AND ALWAYS, point rifle in a safe direction and thoroughly acquaint yourself with all reference points in the diagram. Be sure gun is not cocked and test it by pointing in a safe direction and squeezing the trigger. Pull Operating Slide Handle back to open BB Port cover. By holding the rifle at a slight angle, 22 Crosman Super BB's can slowly be poured from the box (or from the spare magazine) into the Hand Guard groove allowing the BB's to enter the hole for the internal magazine. You may pour remaining BB's into the removable spare magazine in the bottom of the rifle.

2. TO REMOVE SPARE MAGAZINE (CLIP):

With rifle held in one hand, muzzle forward, push the magazine up (into the stock), then forward (toward the muzzle) at the same time pushing the bottom of the magazine forward in a semi-rotating motion. The magazine can then be removed. Slide the cover on the magazine forward. The magazine

can be loaded with 270 Crosman Super BB's. Close slide cover and insert the magazine into the gun in the reverse procedure as explained above. To pour 22 BB's from the spare magazine into the internal magazine, open the magazine slide cover about $\frac{1}{2}$ inch and follow the procedure TO LOAD RIFLE.

3. TO ADJUST REAR SIGHT:

Windage: If you want to shoot to the right, turn windage correction knob clockwise. To shoot left, turn knob counterclockwise. Elevation: If you want to shoot higher, push down and pull peep sight to the rear until it locks in the next recess. To shoot lower, push down on the peep sight blade and move forward until it locks in the next recess.

4. TO SHOOT RIFLE:

With muzzle slightly elevated, place hand on barrel over non-slip grip (identification name) and slide barrel to the rear as far as it will go. (CAUTION: DO NOT place finger or hand over muzzle end of barrel while cocking. DO NOT place finger on trigger while cocking.) Slide barrel forward to extreme full length. DO NOT slam barrel forward when returning to locked position as this will cause BB to override BB retainer and fall out of barrel.

DO NOT cock by pushing barrel into the ground or hard surfaces as you may obstruct barrel or damage crowning. Take aim, squeeze trigger to shoot. Loaded chamber can be checked through BB indicating hole.

5. LUBRICATION:

Lubricate all moving parts through BB indicating hole, and at point where barrel recesses into main tube forward of the front band. With the magazine (clip) removed, and gun upside down, oil at sear and hammer points. Oil sparingly with three or four drops of oil at each point and when parts appear dry. For best results and trouble free performance, use Crosman Special Pellgunoil® only. Never use penetrating, detergent or regular gun oils as they may be harmful to valve seals.

6. CARE OF YOUR GUN:

The Crosman M-1 Carbine BB Air Rifle is a precision built gun of the most modern design and construction. Materials have been carefully selected for quality and long life. The use of hardwood stock, solid steel barrel and precision machined parts attest to this statement. When it is released for shipment, it has undergone numerous, rigid inspections and has been test-fired for performance. Treat it with

M-1

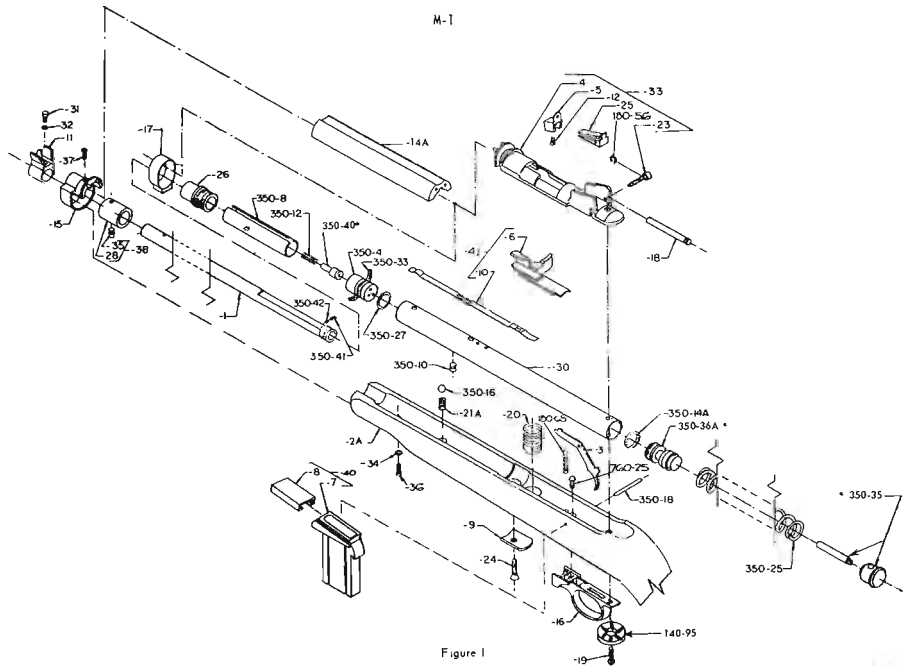

Figure 1

PLACE
Necessary
Postage
HERE

TO: CROSMAN ARMS CO., INC.

EAST CHURCH AT TURKHILL

FAIRPORT, N. Y. 14450

WARRANTY REGISTRATION

IMPORTANT. To properly maintain validity of guarantee, fill in this card and mail to **Crosman Arms Company.** Your record of warranty and guarantee are in the attached instructions.

Your Name: Age:

Address.....

City and State

Occupation:

Gun Model: Date purchased:

Dealer's name:

Address, City and State.....

6. If you own other guns, please note:

Brand:..... Brand:..... Brand:.....

Type:..... Type:..... Type:.....

We are pleased to welcome you to America's fastest growing shooting sport with the purchase of your Crosman.

We would like to send you and three of your friends a copy of our new "Shooting Fun Booklet" if you will furnish their names and addresses.

Please send these friends your "Shooting Fun Booklet":

Name:

Address.....

City and State.....

Name:

Address.....

City and State.....

Name:

Address.....

City and State.....

Your answer to the following questions will be helpful to us in our endeavors to further the shooting enjoyment of our customers.

1. What or who prompted you to buy your Crosman:

2. What kind of shooting will the gun be used for:

Where will you shoot:

3. In what magazines do you read about guns?

4. What features of your gun do you like best:

5. Additional features or changes you would like in your gun:

Crosman Arms Co., Inc., Fairport, N. Y.

(IN CANADA, DUNNVILLE, ONTARIO)

(SEAL OR STAPLE HERE)

"Shooting is **3** Times More Fun!" with a *Crosman*

1 SHOOT RIGHT!

Easy, safe marksmanship or training shooting.

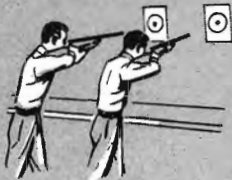

2 SHOOT MORE OFTEN!

Anytime, any season—right in and around your home—in your basement, garage, game room—even in your living room! Just select a proper backstop.



3 SHOOT IN MORE PLACES!

Indoors, outdoors, in limited areas or wide open spaces. A Crosman is a real fun gun to have along on a fishing or camping trip.



PRICE LIST AND ASSEMBLIES FOR: MODEL M-1

MINIMUM CHARGE OF \$1.00

PART NO.	DESCRIPTION	LIST PRICE	PART NO.	DESCRIPTION	LIST PRICE
1-1	BARREL	\$ 7.30	1-32	FRONT SIGHT WASHER	\$.10
1-2	STOCK-WOOD (no longer available) use 1-2A		1-33	REAR SIGHT ASSY. (COMPLETE)	3.15
1-2A	STOCK-CROSWOOD	7.25	1-34	LOCK WASHER.....	.10
1-3	TRIGGER55	1-35	TUBE STUD25
1-4	RECEIVER PLATE AND SIGHT MOUNT.....	.90	1-36	TUBE SUPPORT SCREW10
1-5	REAR PEEP SIGHT.....	.55	1-37	STOCK CLAMP SCREW10
1-6	OPERATING SLIDE60	1-38	SUPPORT RING ASSEMBLY	1.40
1-7	MAGAZINE75	1-40	MAGAZINE ASSY	1.00
1-8	MAGAZINE COVER15	1-41	OPERATING SLIDE ASSY. (incl. -6 & -10)95
1-9	MAGAZINE SUPPORT PLATE45	140-95	TRIGGER GUARD LOCK WASHER.....	
1-10	BB PORT COVER.....	.15		(ADDED 6/10/68)10
1-11	FRONT SIGHT.....	.40	180-56	RETAINER RING.....	.10
1-12	PEEP SIGHT SPRING10	180-65	TRIGGER SPRING10
1-14	HAND GUARD-WOOD(no longer avail.) use 1-14A		350-4	BARREL CAP.....	.80
1-14A	HAND GUARD-CROSWOOD	1.30	350-8	SPACER50
1-15	FRONT BAND45	350-10	GUIDE SCREW10
1-16	TRIGGER GUARD75	350-12	VALVE SPRING10
1-17	COLLAR40	350-14A	TEFLON RING45
1-18	LOCATING STUD50	350-16	BARREL LOCK BALL.....	.10
1-19	STOCK SCREW10	350-18	TRIGGER PIN10
1-20	MAGAZINE SPRING10	350-25	PISTON SPRING50
1-21A	BARREL LOCK SPRING10	350-27	"O" RING SEAL15
1-23	WINDAGE SCREW25	350-33	FELT10
1-24	STOCK SCREW10	350-35*	STOP AND PLUG ASSY85
1-25	SIGHT ELEVATOR.....	.55	350-36A*	HAMMER AND PISTON ASSY	1.00
1-26	TUBE BEARING50	350-40*	POP VALVE ASSY60
1-28	SUPPORT RING.....	.95	350-41	RETAINER SPRING10
1-30	TUBE.....	1.15	350-42	RETAINER BALL (.140").....	.10
1-31	FRONT SIGHT SCREW10	400-16	OVER SIZE RETAINER BALL (.156")10
			760-25	TRIGGER GUARD SCREW10
			E.V.P.	EXPLODED VIEW & PARTS LIST	1.00

NOTES: *Available factory assembly only. Do not order Components.

"CROSWOOD" is Crosman Brand Name for Plastic Stock and Handguard. Parts 1-2, 1-14 and 1-21 are Mating Parts-Wood. Parts 1-2A, 1-14A and 1-21A are Mating Parts-Croswood.

MINIMUM ORDER \$1.00. Prices subject to change without notice. Check or money order in the amount of total purchase must accompany parts order. Parts will be shipped prepaid.

the same fine care that you give your other valued possessions and it will give you many hours of care-free pleasure and enjoyment. Keep your rifle clean, free of dirt and grit from entering the barrel and internal mechanism. When storing it, be sure to unload it and not cocked. Wipe off metal parts with an oily cloth gently to prevent rust and preserve the finish. **DO NOT USE DETERGENT OILS OR GUN SOLVENTS** as they are harmful to seals and the finish.

7. REPAIR SERVICE:

It is not necessary for your dealer to replace your gun. Your Crosman gun can be serviced at one of the authorized Crosman Service Stations in your state (listed on the attached list.) **DO NOT** return gun to factory without written permission.

Our Service Stations are equipped to make warranty repairs on Crosman guns, using original Crosman parts, within ninety (90) day warranty period. **GUARANTEE CERTIFICATE** must be filled out, and accompanying your gun in order to qualify for service.

WARRANTY is void if gun has been disassembled or, in the judgment of the service station, has been tampered with, abused or misused. Always include a description of the malfunction with the gun.

IMPORTANT: The guarantee certificate should be properly filled out at time of purchase and must accompany your gun when qualified warranty service is required during the 90-day period. Where the guarantee certificate has been misplaced, a verification (sales slip) from your dealer will suffice.

Warranty

Should this unit become inoperative, due to defective parts or workmanship, Crosman Arms Company fully guarantees it will be repaired to function as originally designed. This guarantee does not imply that worn finish, missing parts and abused components will be replaced/repaired at no charge.

ANY OTHER STATEMENT MADE OR IMPLIED REGARDING THE WARRANTY AND NOT INCLUDED HEREON IS INVALID.

GUARANTEE CERTIFICATE

IMPORTANT

Keep this certificate. Cut out and take to Crosman Authorized Service Station to qualify for warranty service.

Customer's Name.....

Street.....

Town.....State.....Model.....

Dealer's Name.....Date Purchased.....

CROSMAN ARMS CO.

Fairport, N. Y. 14450

Customer Service Department

TO: _____



ARMS COMPANY, INC.

A Subsidiary of The Coleman Co., Inc.

**980 TURK HILL ROAD
FAIRPORT, NEW YORK 14450**

Authorized Service Stations

"THIS LIST IS REVISED PERIODICALLY. BEFORE RETURNING A GUN TO A LISTED STATION. VERIFY THAT IT IS CURRENTLY AN ACTIVE CROSMAN SERVICE STATION."

The nationwide network of Factory Authorized Service Stations listed hereon have been established for your convenience and in the interest of providing fast, local service on both In-Warranty and Out-Of-Warranty guns. All of these Stations are fully equipped to handle repairs on all models of Crosman Pellguns and BB guns. **DO NOT** return your gun to the factory. Refer to the nearest Service Station on the list.

The guarantee certificate in the Owner's Manual, packed with each Crosman gun should be properly filled out at time of purchase and must accompany your gun when qualified warranty service is required during the 90-day period. Where the guarantee certificate has been misplaced, a verification (sales slip) from your dealer will suffice. Should this unit become inoperative, due to defective parts or workmanship, Crosman Arms Company fully guarantees it will be replaced to function as originally designed. This guarantee does not imply that worn finish, missing parts and abused components will be replaced/repared at no charge.

ANY OTHER STATEMENT MADE OR IMPLIED REGARDING THE WARRANTY AND NOT INCLUDED HEREON IS INVALID.

NOTE: It is illegal for anyone other than a bona fide dealer, manufacturer, or person holding a valid Federal Firearms License to ship Air and CO₂ Pistols through the United States mail. Ask your local dealer to mail it for you. These units may, however, be sent by an individual, via railway express in most states.

ALABAMA			
BIRMINGHAM	John O. Spinks - 509 12th Ave. (Midfield, Ala.) 35228	205-787-1711	
CLANTON	Rudolph's Gun Repairs - 2023 4th Ave. North 35045	205-755-5089	
HELENA	Joe's Fixit Shop - Rt. 1, Box 488 35080	205-822-3010	
	17 miles So. of Birmingham on Route 31		
LANGDALE	Haves Store - Box 187 35864		
MONTGOMERY	Todd's Gun Store - 241 No. Court St. 36104	205-263-3078	
SELMA	Walker Arms Co. - Rt. 2, Box 38 36701	205-872-3888	

ARIZONA			
PHOENIX	Bohm's Incorporated - 3440 East Van Buren 85008	602-275-1262	
YUMA	Frank's Gun Shop - 2259 4th Ave. 85364		

CALIFORNIA			
ALAMEDA	Lloyd's Pelgun Repair - 1238 Pearl St. 94501	408-522-4709	
ANAHEIM	K. Hatfield Crossman Repair - 240 E. Adele St. 92805	714-828-0986	
	Neals Sporting Goods 92804		
ARTESIA	Ray's Sporting Goods - 18925 Norwalk Blvd. 90701	213-924-1714	
BAKERSFIELD	Valley Gun Shop - 4300 Gordon 93307	805-832-3088	
BERRY CREEK	Bald Rock Gun Shop - 95916	916-533-4653	
DALY CITY	Daly City Gun Store - 6694 Mission St. 94014	415-755-7434	
DUARTE	Campers Haven - 2402 E. Huntington Drive 91010	213-359-1255	
FRESNO	R.V. Products, Inc. - 6310 N. Blackstone 93701	209-264-0455	
FULLERTON	Neals Sporting Goods - 601 S. Euclid 92653 (Pick-up station only)	714-871-5988	
LANCASTER	Christensen's Guns & Sporting Goods - 44936% D. Beach 93534		
LONG BEACH	Ball & Frank Sporting Goods - 345 Long Beach Blvd. 90812	HE-619-87	
LOS ANGELES	Las McMurray & Son - 15446 Cabrito Rd. (Van Nuys) 91406	213-781-1921	
	Perry's Sporting Goods - 4353 Broadway (Hawthorne) 90250	213-675-3816	
	Al's Gunsmith Shop - 371 East Columbia 91767 (Pomona)	714-823-2922	
	Neals Sporting Goods - 27 Fashion Island 92660	714-644-2121	

NEWPORT BEACH			
	(Pick-up station only)		
NORTH HIGHLANDS	Dan's Nu-Matic Repair - P.O. Box 496-7442 Watt Ave. 95660	916-331-1269	
OXNARD	Oxnard Sporting Goods - 140 North A St. 93030	805-483-2638	
PACIFICA	Pacifica Sports Center, Inc. - 2130 Palmetto Ave. 94044	415-359-0546	
PETALUMA	Anderson Gunsmithing - 2485 Petaluma Blvd.N. 94952	707-763-3852	
PORTERVILLE	Sportsmen Sport Goods - 50 N. Main St. 93257	209-784-1581	
RIVERSIDE	Bob Stewarts Gun Shop - 3830 Jurupa Ave. 92506	714-692-5400	
SAN CARLOS	Walt Ricci - P.O. Box 991 94070		
SAN DIEGO	Buckman's Gun Shop - 3836 University Ave. 92100 (Pick-up station only)		
	Krasne's Inc. - 568 Sixth Ave. 92101	715-239-0181	
	Naill Instrument - 1882 Greenfield Dr. (El Cajon) 92021	714-447-8991	
	Woodlander's Sporting Goods - 300 A East Las Tunas Dr. 91776	213-295-9611	
SAN GABRIEL	Houston Hobby Shop, Inc. - 930 Town & Country 95128	408-241-4940	
SAN JOSE	Neals Sporting Goods - 219 East 4th St. 92705 (Pick-up station only)	714-547-5723	
SANTA ANA	Pelch & Son Sporting Goods - 1207 State St. 93101	805-966-7467	
SANTA BARBARA	Dale D. Baldrige, Gunsmith - Rock Creek Rd. 96087		
SHASTA	C. bowser Reloading & Ammo Shop - 742 E. Main St. 95202	209-465-7415	
STOCKTON	Las McMurray & Son - 15446 Cabrito Rd. 91406	213-781-1921	

COLORADO			
ARVADA	Al's Sporting Goods Co. - 5300 Wadsworth Ave. 80002	303-424-7778	
DELTA	Robert J. Mansell, Gunsmith - 1252 Grand Ave. 81416	303-874-9334	
PALISADE	Ray's Gunsmith Shop - Rt. 1, Box 366 81526		

CONNECTICUT			
BRISTOL	Horchler's Gun Shop - 8 First St. 06010	203-682-0530	
ELMWOOD	John Baronowich - 32 Vine Hill Rd. 06110	203-561-0120	
SIMSBURY	K.P. Firearms Service Station Co. - Box 274 06070		
WALLINGFORD	Modern Guncraft - Dennis Katona, Jr. - 1406 Durlam Rd. 06492	203-265-1015	

FLORIDA			
FORT LAUDERDALE	Don's Crosman Repair - 502 N.E. 13th St. 33304	305-565-0448	
MIAMI	Air Gun & Rifle Repair - 2942 N.W. 22nd. St. 33142	305-534-1728	
	Toby's Inc. - 7450 N.W. 27th Ave. 33147	305-691-3711	
MT. DORA	A.W. Peterson Gun Shop - 1893 Old Highway 441, 32757	904-383-4258	
ORLANDO	Jay's Sports Den - 740 Hastings St. 32808	305-299-4324	
ST. PETERSBURG	Bill Jackson, Inc. - 1100 4th St. So. 33701	813-896-8634	

GEORGIA			
Roach Sporting Goods - 273 E. Paces Ferry Rd.N.E. 30305	404-261-8000		
Elkhorn Gun Shop - Rt. 3, Flat Shoals Rd. 30207	404-483-2143		
The Gun Corral, Inc. 2827 E. College Ave. 30033	404-377-7288		
Walker Arms Co., Inc. - 1360 West Taylor St. 30223	404-228-4223		
Southern Auto Store - 122 First St., S.E. 31768	912-985-5774		
Mac's Gun & Tackle Shop - Corner Hwy. 11 & 189 30738	404-462-2386		

HAWAII			
HONOLULU	King's Sporting Goods - King at Smith Sts. 96817	808-538-6764	
WAIKALU	Waipahu Bicycle & Sporting Goods - 94-320 Depot St. 96797		

IDAHO			
IDAHO FALLS	Paul's Repair Service - 1095 Ada Avenue 83401	208-523-2481	

ILLINOIS			
BELVIDERE	Jones & Bailey - Logan Ave. at S. Main St. 61008	815-543-9086	
CHICAGO	Cornet's Rod & Reel Service - 6532 N. Clark St. 60626	312-743-2980	
DANVILLE	Johnson's Sporting Goods - 794 Lee St. 60016	312-299-7774	
	S & J Sport Shop - 423 East Main 61832	217-442-8979	
GENEVA	The Outdoorsman Sporting Gds. Co. 105 West State St. 60134	312-232-4680	
OAK LAWN	Lain's Associated Guns, Inc. - 4542 W. 95th St. 60453	312-857-9751	
PEKIN	Don's Gun Repair - Route 2, Glenmar Dr. 61554	309-346-5242	
WESTMONT	D & E Steidinger - 9 S. 276 Cass Avenue 60559	312-968-3359	

INDIANA			
ANDERSON	Hodson & Son Pel Gun Repair - RR 7, Box 18 Scatterfield Rd. South 46011	317-643-2055	
BLUFFTON	Myers Gun Shop - N. Wabash Avenue 46714	219-824-2230	
EVANSVILLE	Rajo Corporation - 2203 W. Franklin St. 47712	317-422-6845	
FT. WAYNE	Robert E. Lutter - 3547 Auer Drive 46815	219-485-8319	
	Schlatter Hardware Co., Inc. - 5310 Merchandise Dr. 46805	219-484-4161	
HIGHLAND	C-K Sports & Hobby Service - 9553 Indianapolis Blvd. 46322	219-923-6809	
INDIANAPOLIS	Broad Ripple Sports Shop - 1015 E. Westfield Blvd. 46220		
	Windsor Gun Shop - 8510 Southeastern Ave. 46239	317-862-2512	
KOKOMO	Mal's Out-Of-Doors Store - 1813 N. Davis St. 46901	317-452-4149	
MISHAWAKA	Robert Bobson, B & B Gun Repair - 801 S. Spring St. 46544	219-255-0712	
PLAINFIELD	Galyen's Trading Post - U.S. 40, 46168 (Pick-up station only)	317-639-6277	

IOWA			
BETTENDORF	Air & Gas Gun Repair - 1125 Valley Dr., Box 53, 52722	319-355-3282	
BURLINGTON	Drake Hardware - 106 Washington St. 52602		
CEDAR FALLS	Nelson's Engine Shop - 620 State St. 50613		
DES MOINES	Tony's Gun Shop - 2110 E. 14th St. 50316	515-262-6898	
	Glenn's Real Repair Service - 1738 Fearer St.	515-262-2990	

KANSAS		
GREAT BEND	Phillips Sporting Goods - 2016 Broadway 67530	316-793-3291
WICHITA	Wigwam Rod & Reel Repair - 233 Mathewson 67203	316-264-5891
	Rays Rod & Reel Repair Service - 414 Pettie St. 67211	316-267-9462

KENTUCKY		
LOUISVILLE	Doerr's Sporting Goods - 1515 Bardstown Rd. 40205	502-451-7327

LOUISIANA		
NEW ORLEANS	Crescent Gun & Repair Co. - 2401 So. Claiborne Ave. 70125	504-525-9752

MARYLAND		
BALTIMORE	Peltzer's Sport Shop - 2311 E. Monument St. 21200	301-676-3130
CHILLUM	Apple Hardware Inc. - 5918 Riggs Road 20783	301-559-1313
EDGEWOOD	Peltzer Sport Shop, East - 1015 Edgewood Rd. 21040	301-676-6050
GLEN BURNIE	Bart's Sporting Goods - 1418 Ritchie Highway 21061	
PASADENA	Bart's Sporting Goods - 2435 Mountain Rd. 21122	

MASSACHUSETTS		
CHICOPEE	Chicopee Sport Center - 48 Cabot St. 01013	413-592-1280
GRANBY	L.E. Bellrose & Son - 21 Forge Pond Rd. 01033	413-467-4263
NORTHBORO	Forest Orchard Archery & Spt. Gds. Co. 19 Blake St. 01532	617-393-8263

MICHIGAN		
BAY CITY	Breen's Sport Shop - 807 Columbus Ave. 48706	517-892-2011
DAVISON	Frank & Jacks Crosman Service - Lot 74 Gunwood Davison East Mobile Estates 48423	517-892-4595 313-653-6786

DETROIT	ACO Sportsman Service Inc. - 13501 VanDyke 48234	313-365-4610
GRAND HAVEN	Kooiman Sport Shop - 635 Fulton 49417	
INKSTER	Irv's Gun Shop - 27367 Michigan Ave. 48141	
LANSING	B & W Supply Co. - 412 Baker St. 48910	
OSCODA	Lee's Place - 5650 N. M-171 48750	517-739-5222
SPRUCE	Will's Gun Shop - 5603 No. Hubbard Lake Road 48762	

MINNESOTA		
DEERWOOD	T.R. Taber - Route 1 56444	218-764-3104
MINNEAPOLIS	B & B Supply Co. - 4501 Minnehaha Ave. S. 55400	612-724-5230
	Berntson Gun Shop - 926 Mississippi St. (Fridley) 55432	612-560-1618
ST. PAUL	Jack Frost Live Bait - 854 Rice St. 55117	612-488-4603

MISSISSIPPI		
JACKSON	May & Jackson - 838 W. Capitol St. 39200	
MERIDIAN	Normandy Service Co. - 6407 - 1st Key Field 39301	601-482-0811

MISSOURI		
HUDSONVILLE	Joe's Gun Shop - 2358 Barry St. 49426	
LEES SUMMIT(Kan.City)	Sports Center Service Dept. - 15 W. 3rd. St. 64063	816-524-0283
ST. LOUIS	Griffin Gun Shop - 4416 Morganford Road 63116	314-752-7643

MONTANA		
BILLINGS	Herb's Gun Shop - 2412 Frist Ave. N. 59101	406-248-8918
ROSCOE	Jim's Gun Shop - Box 13 59071	406-328-3633

NEBRASKA		
BEATRICE	Ult's Sporting Goods - 204 North 5th St. 68210	402-222-4222

**ASHEVILLE
CHARLOTTE
DURHAM
FAYETTEVILLE
WINSTON-SALEM**

NORTH CAROLINA		
Don's Gun Shop - 371 Swannanoa River Road 28805	704-253-1095	
Spencer M. Fulp, Gunsmith - 1904 Anderson St. 28200	704-376-7017	
Don Hill's Lock & Gun Shop - 2802 Hillsborough Rd. 27705	919-286-0253	
Bull's Eye Gunshop - 990 McPherson Church Road 28304	919-425-8560	
The Air Rifle Center - 1804 Sprague St. S.E. 27107	919-788-2646	

OHIO		
AKRON	Clarkins Sporting Goods Repair - 3200 Arlington Rd. 44312	216-644-4182
CINCINNATI	Ed Brendamour Inc. - 130 E. 8th St. 45202	
CLEVELAND	Jim Derek's - 21135 Lorain Rd. 44126 (Pick-up Station only)	216-734-1412
	R & F Hardware - 11915 Kinsman Rd. 44120	216-751-4002
COLUMBUS	Zanes Gun Rack - 4167 N. High St. 43214	614-263-0369
DAYTON	Nevill's Gun Service - 2222 Old Troy Pike 45404	513-233-6520
FAIRVIEW PARK	Bob's Crosman Repair - 4096 W. 227 St. 44126	216-734-5817
FREMONT	Fremont Gun & Athletic Supply - 121 No. Arch St. 43420	419-332-8961
LIMA	Ace Alarms & Locksmith - 909 Catalpa Ave. 45804	419-229-3015
MASSILLON	The Trading Post - 412 Erie St. S. 44646	216-833-7761
MOGADORE (Akron)	Dan Boyles Crosman Repair - 3391 State St. 44260	216-673-9676
READING(Cincinnati)	Deisch Gun Repair - 1020 Reading Road 45215	513-554-1100
ST. MARYS	Weapon Smithery - 1005 Linden Ave. 45885	
TOLEDO	Young's Crosman Service - 2621 - 102nd St. 43611	419-726-6694
WARREN	Jones Robbins (Sportland) - 104 High St. N.W. 44481	216-392-6161
YOUNGSTOWN	Pinchot's Air Gun & Tackle Service-1643 Lansdowne Blvd.44505	216-743-9121

OKLAHOMA		
CLINTON	Shamburg's Wholesale Sporting Goods - 400 Frisco Ave. 73601	405-323-0209
KINGFISHER	The Sport Shop - Bower Bldg. Main & Will Rogers 73650	405-375-5130
TULSA	Peter Meydag - 2231 S. 84th E. Ave. 74129	918-627-7519

OREGON		
GRANTS PASS	Ralph Basse, Gunsmith - 1008 N.E. Healey St. 97526	503-479-4052
PORTLAND	Ollie Damon, Inc. - 4530 S.E. Hawthorne 97215	503-232-3193

PENNSYLVANIA		
ALLENTOWN	S.W. Gaugler, Gunsmith - 1503 E. Livingston St. 18103	215-432-9952
BRISTOL	Bristol Gun & Tackle Shop - 5 Pond St. 19007	215-788-9185
ERIE	Harry E. Mueller - THE KEY MAN - 445 W. 8th St. 16502	
	LaJal Service - 5451 Peach St. 16509	814-866-0151
GIBSONIA	A. Christian Uhl - 5000 Lakewood Rd. 15044	412-443-1160
LEBANON	Martin Lewan Sporting Gds. Store - 433 North 9th. St. 17042	717-273-3148
MOUNTAINTOP	Miller's Sport Shop - 2 Summit View Dr. 18707	717-474-6931
(Wilkes Barre Area)		
NEW KENSINGTON	Jacob's Sport Goods - 4th Ave. & 9th St. 17072	
PITTSBURGH	Tackle Service - 2815 Brownville Rd. 15227	412-881-3324
SPRING CITY	John L. Keely - R.D. 1 19475	215-495-8874

RHODE ISLAND		
WARWICK	Georges Sporting Gds. Inc. - 1089 Bald Hill Rd. 02886	401-828-2397

SOUTH CAROLINA		
GREENVILLE	Art Delany's Sporting Goods - 2021 Wade Hampton Blvd.29601 (J.A. Sammons Pick Up Station)	

BEATRICE	Uhl's Sporting Goods - 204 North 5th St. 68310	402-223-4233
HASTINGS	Sporting Goods Inc. - 232 N. Lincoln St. 68901	402-462-6240
NEBRASKA CITY	The Sport Shop - 707 Central Ave. 68410	402-873-6020
OMAHA	Powers Gun Shop - 6782 Pratt St. 68104	402-558-3777
NEVADA		
LAS VEGAS	Christensen Shooter's Supply & Sporting Goods 3979 W. Charleston Blvd. 89102	702-878-4724
RENO	Alpine Reloading Room - 1100 S. Wells Ave. 89502	702-323-5319
NEW HAMPSHIRE		
WONALANCET	Baer's Gun Shop - Rt. 113A (N. Sandwich) 03887	
NEW JERSEY		
BLACKWOOD	Jay's Sport Center - 1000 N. Black Horse Pike 08012	609-227-8793
DIX HILLS	Joseph W. Zeiser - 3 Charter Court 11746	516-586-5704
Pick up station for Target Locksmith		
ELIZABETH	Ross Sport Shop - 1053 Elizabeth Ave. 07201	
KEARNY	J & J Firearms Co. - 445 Kearny Ave. 07032	201-998-7979
LAKEHURST	Krugs Sport & Tackle Shop - 11 A Rt. 37, 08733	201-657-8202
SADDLEBROOK	Targeters, Inc. - Rt. 46 & 5th 07662	
SOMERSET	Fred W. Lewis - RD # 3 - Box 312 - L. Ellison Road 08873	201-844-8912
UNION	Young's Air Gun Repair - 720 Colonial Arms Rd. 07083	
YAROVILLE	Harry's Army Navy Store - R. 130 & Klockner Rd. 08620	609-585-5450
NEW YORK		
ALABAMA	Richard Eaton Gunsmith - 1377 Lewiston Road 14003	716-948-9629
ALBANY	Taylor & Vodney Inc. - 303 Central Ave. 12206	518-472-9183
BETHPAGE	Gun Gallery Inc. - 271 Central Ave. 11714	516-433-3060
BELLMORE	Norman Richman Gunsmith, Inc. - 2560 Sunrise Hwy. 11710	516-826-8989
EAST MEADOW (LI)	Mr. Jerry Schmurr - 123 Lorraine Gate 11554	516-796-0842
EAST NORTHPORT	Larkfield Sport Center - 248C Larkfield Rd. 11731	
(Pick up Station for E. John Boracci)		
ENDICOTT	Murray Brown - 609 N. Duane Ave. 13760	
HORSEHEADS	Bob's Bow Hunting & Sporting Gds. - 156 Ithaca Rd. 14845	607-739-1949
(Elmira-Corning Area)		
SO. GLEN FALLS	Johnson's Gun Repair - 7 Marion Ave. 12801	518-792-9177
HUNTINGTON	Guns & Ammo - 269 New York Ave. 11743	516-HA1-1928
HUNTINGTON STATION	The "Camp-Site" - cor. N.Y. Ave. & W. 16th St. 11746	516-271-4969
(Pick up Station Only)		
ISLIP	Berg's Gun Shop - 130 Freeman Ave. 11751	516-581-7525
ITHACA	M.D. Repair Service - Box 251 - 515 W. Buffalo St. 14850	607-273-7970
KERHONKSON	Mr. Edward Pomerantz - Trail Sport Shop 12446	
LINDENHURST	Charles Bait & Tackle - 175 E. Montauk Hwy. 11757	516-TU4-2021
MANHASSET	Target Gun & Locksmiths - 605 Plandome Road 11030	516-MA7-6286
MIDDLETON	Bob Lounsbury Spt. Goods - 104 North St. 10940	
MONTICELLO	Sam Greene, Gunsmith - 45 Floral Drive 12701	914-794-7717
	Davco Stores - 305 Broadway Box 152 12701	914-794-5225
	M.F. Kinney Corp. - 364 Broadway 12550	914-561-3268
	Rapids Gun Shop - 7811 Buffalo Ave. 14304	716-284-4547
	The Sports Mart - 828 Ford St. 13669	315-393-2865
	Royal Fishing Tackle Co., Inc. - 127 West Main St. 11772	516-475-5410
	Carpenter's Gun Works - Box C, Gunshop Rd. 12568	914-562-8089
	E. John Boracci, Gunsmith - 2048 Seaford Ave. 11783	516-221-8229
	Davis Sport Shop - 7 Johnsontown Road 10974	414-753-2191
	Sportsman Repair Shop - 448 James St. 13200	315-422-2058
	Dave Kielon-Gunsmith - 57 Kittleberger Park 14560	716-872-2256

GREENVILLE	(J.A. Sammons Pick Up Station)	803-895-3855
J.A. Sammons - Route 2, 29651		
LaFRANCE	Bowen Distributors - 2 Circle St. 29656	803-646-7613
TENNESSEE		
GALLATIN (Location #2)	Greenfield's - 353 E. Main St. 37066	
JOHNSON CITY	George Hendrix's Gun Shop - 107 E. 10th St. 37601	615-926-3035
KNOXVILLE	Adrian Dow - Route 28 Nixon Road 37920	
MEMPHIS	E.G. Hagstrom - 2008 Janis Drive 38116	901-397-4145
	Dowdle Sporting Goods - 2896 Walnut Grove Rd. 38100	
	Dowdle Sporting Goods - 543 Perkins Extended 38100	
	Quality Tire Co. - 4228 James Rd. 38128	901-386-7660
	Greenfield's - 114 W. Vine St. 37130	
MURFREESBORO	(Location #3)	
NASHVILLE	Gun City U.S.A. - 573 Murfreesboro Road 37210	615-254-8608
WHITE HAVEN	Dowdle Sporting Goods - 4283 Highway 51 So. 31116	
TEXAS		
BEAUMONT	Moses Gun & Locksmith - 1521 College St. 77701	
CORPUS CHRISTI	Texas Gun Shop, Inc. - 4518 S. Padre Island Dr. 78411	512-854-4424
CORSICANA	Chaffee Crossman Repair - 420 South 30th St. 75110	214-874-5174
DALLAS	Wiley's Gun - 539 W. Jefferson 75208	214-WH6-3528
EL PASO	Ed Budu's Custom Gun Shop - 5100 Harlan Dr. 79924	915-751-8273
INGLESIDE	Point's Gun Shop - P.O. Box 313 78362	512-882-8815
ODESSA	Wagner's Tackle Shop - 1104 Nabors Lane 79760	915-337-6270
PASADENA	The Gun Shop - 1906 E. Southmoor 77502	713-472-1745
PORT ARTHUR	Ken's Gun Clinic - 3090 25th St. 77640	713-983-5920
SAN ANTONIO	Don's Gun Shop - 3329 Fredericksburg Rd. 78201	512-735-1931
	Gasman's Archery & Air Rifle Hdg. - 102 Jackson Keller 78216	512-822-7131
UTAH		
LEHI (Utah Co.)	Hutch's - 50 E. Main St. 84043	
MAGNA	Falvo Sporting Goods - 8975 W. 2700 So. 84044	801-297-9923
OGDEN	Merrill D. Shomaker - 1604 - 20th St. 84401	801-399-2234
VERMONT		
BRATTLEBORO	Clapp's Sporting Goods Co. - 157 Main St. 05301	802-254-4260
VIRGINIA		
CHARLOTTESVILLE	Carter's Gun Works - 2211 Jefferson Park Ave. 22903	703-296-6363
WASHINGTON		
SEATTLE	Saylor's Gun Shop - 9426 15th Ave. 98106	206-R07-3424
SPOKANE	Art's Repair Service - 4104 Grand Ave. 99203	509-R17-1312
TACOMA	Welcher's Gun Shop - 6400 Pacific Ave. 98408	206-472-1113
WEST VIRGINIA		
FAIRMONT	The Sport Store - 312 Monroe St. 26554	304-363-0220
WISCONSIN		
FOND DU LAC	Jack's Lock & Gun Shop - 37 Forest Ave. 54935	414-922-4420
GRAFTON	Fall's Gun Repair - 1457 River Bend Rd. 53024	414-377-1514
MAUSTON	R & R Shooters Supplies - Rt. 1 Box 32 53948	608-847-4562
MILWAUKEE	Martin's Repair Service - 8409 W. Burleigh St. 53222	414-873-3220
SO. MILWAUKEE	N. Hintz Sport & Marine Inc. 1235 Milwaukee Ave. 53172	414-762-1281
TWO RIVERS	Gill's Sporting Goods - 1918 Washington St. 54241	414-792-7520

ONTARIO	CANADA Crosman Arms (Canada) Ltd. Broad St., Dunnville
GLASGOW C.2 SCOTLAND	GREAT BRITAIN James W. McCallum James McCallum, Ltd. - 62 Robertson St.
HAUTS DE SEINE	FRANCE Galan Armes et Munitions International 59, Bd. Voltaire - 92 - Asnieres
FRANKFURT/MAIN	GERMANY Franz A. Dieler, K.G. - Wilhelm-Leuschner Str.
20124 MILANO	ITALY Beretta Fiocchi S.P.A. - Via Fabio Filzi 27
CARACAO	NETHERLAND ANTILLES Piar Pharmacal-Kerstraat 26
MANILA	PHILIPPINES Associated Trading Corp. - 557 Rosario Binondo
BAYAMON CAPARRA HEIGHTS	PUERTO RICO New York Dept. Store Leon Lyon Martin - LaArmeria Metropolitana - Box 10974(00920) New York Dept. Store - San Patricio Shopping Center
MAYAGUEZ SANTURCE	J. Cavallieri Applicances - McKinley 59 New York Dept. Store - Stop #17 Max Steck - Calle Monserrate 620
TRANAS	SWEDEN Stig Hjelmquist - Box 172
ST. CROIX	VIRGIN ISLANDS St. Croix Auto & Hardware - Christiansted Treasure Trove
ST. THOMAS	Lawrence A. Creque - P.O. Box 637

This is a Limited Offer Only!
VOID Thirty Days after Purchase of Gun
CROSMAN CO₂ SHOTGUN CERTIFICATE
SPECIAL FACTORY DIRECT OFFER

This certifies that I am a Crosman gun owner, which qualifies me for the purchase of the Trapmaster Model 1100 at a special cost to me of only **\$29.95** (regular **\$49.95**), or the complete Trapmaster set, Model 80, as shown on reverse, for only **\$49.95** (regular **\$89.95**).

My payment for the Model 1100 of \$29.95, plus \$2.50 for shipping and handling charges, total \$32.45 (check)
OR
for the complete Trapmaster # 80 set at \$49.95, plus \$4.50 for shipping and handling charges, total \$54.50 (check)
is enclosed: check money order

I purchased my Crosman gun, Model No. _____ on _____ at _____
(DATE) (WHERE PURCHASED)
located _____
(ADDRESS)

CUSTOMER'S SIGNATURE _____

COMPLETE ADDRESS (PLEASE PRINT)
NAME _____
STREET _____
CITY _____ STATE _____ ZIP _____

SHOOT TRAP

with Crosman's new CO₂ Shotgun **pull!**



The Sport.

CO₂ Trap the most exciting new shooting sport ever introduced, is now available for the whole family. It's economical, too. Costs only a fraction of powder shotgun shooting. Perfect for spacious home areas, club houses, camps, even your basement can become a skeet range! CO₂ Trap is the fantastic new development for complete family shooting fun.

Reloading Kit
Now Available.

The Shotgun.

The Crosman CO₂ Trapmaster shotgun is a full size shotgun. It looks like, feels like, shoots like the real thing. And it has features that other shotguns do not have—because it has adjustable CO₂ power for limited area shooting.

The Shells.



The Trapmaster shoots standard No. 8 shot from Crosman CO₂ Shotshells. The load of over 55 lead-chilled shot produces a consistent pattern, assuring a clean target break every time. The system has an effective range up to 40 feet. about \$3.00 per 100

The Targets.

CO₂ Trap breakaway targets are shaped like real clay pigeons.



Clay Targets



Reusable Targets

The domed plastic targets have rings that break away when they are hit. Then they are quickly put together and used over and over again.

Also Available—Miniature Crosman Clay Targets.

The Trap.



The specially-designed Crosman CO₂ trap provides every thrill of powder shotgun trap shooting. Now, trap and skeet shooters can shoot far more often at far less cost. The Crosman CO₂ trap and trap system is excellent for beginners. And great practice for you bird hunters, as well. It's the first economical shotgun system for everyone. Standard Trap equipment includes: Remote Foot Release to permit individual shooting. Auxiliary arm for conversion to MO-SKEET-O shooting. about \$32.00

FAMILY GUNS. Be a two gun CO₂ trap family. Get an extra Trapmaster shotgun when you buy your CO₂ Trap system, so your son can learn with his own gun. It's a great way to get close to your boy.

See the new Crosman CO₂ trap shooting system at your dealer's now. Everything you need comes in one package. Trapmaster CO₂ shotgun, 100 shotgun shells, 10 CO₂ Powerlets, 25 reusable targets, and the new skeet trap. The entire CO₂ trap system sells for under \$90.00. The Trapmaster shotgun alone sells for less than \$50.00. Pick yours up today.

CROSMAN TRAPMASTER MODEL 1100 CO₂ SHOTGUN SPECIFICATIONS

ACTION: One stroke side cocking single shot

BORE: .380 true cylinder bore.

OVERALL LENGTH: 46 1/2"

LENGTH OF PULL: 14 1/4"

DROP AT COMB: 1"

DROP AT HEEL: 2"

SIGHT: Metal bead front

POWER: Crosman Giant CO₂ Powerlets

SAFETY: Positive Cross bolt safety

STOCK AND FOREARM. Contoured hardwood—walnut finish

BARREL: Full rib 28" true cylinder

PATTERN: Approximately 14" dia. at 40 ft.

WEIGHT: 6 1/4 lbs. about \$50.00

The Fun Guns from
Crosman

Crosman Arms Co., Inc., Fairport, N. Y. 14450
Crosman Arms Co. (Canada) LTD., Dunnville, Ont.

For more information
Write Dept. P150
"Answers to your
Questions sheet."